

14PI Heavy Duty Pipe Tandem Axle

G.V.W.R.	14,000#	AXLES	Two 7,000# EZ Lube w/Electric Brakes
G.A.W.R. (Ea. Axle)	7,000#	SUSPENSION	Multi-Leaf Slipper Spring w/Equalizer
COUPLER	Adjustable 2-5/16" 14K Cast	TIRE	ST235/80R16 Load Range E
SAFETY CHAINS	3/8" Grd. 70 w/Safety Latch Hook (2 each)	WHEEL	16 x 6 Heavy White Mod 8 Bolt
JACK	7,000# Drop Leg Jack Wind (Bolted On)	FLOOR	2" Pine
TONGUE	6" Channel Fold Back	LIGHTS	D.O.T. Stop, Tail, Turn & Clearance
TOP RAIL	3" Square Tube Square Back	ELEC. PLUG	7-Way RV
FRAME	5" x 3" x 5/16" Angle	FINISH (Prep)	Steel is Cleaned to Ensure a Professional Smooth Finish.
CROSSMEMBERS	3" Channel	FINISH	Superior Quality Finish is Applied with Pin-Stripping for a Highly Decorative and Protective Finish.
UPRIGHTS	15" Tall - 3" x 2" x 3/16" Angle		
FENDERS	9" x 72" Double Broke Diamond Plate w/ Back		

Standard Features

- Adjustable 14K Cast Coupler
- Safety Chains Attached w/Cold Rolled Eyelets
- 7K Set Back Jack (Bolted On)
- Lower Jack Support Plate
- Fold Back Tongue (14' and longer)
- Reflective Marker Tape
- Tie Down Pockets
- 3" Square Tube Top Rail Capped w/Self Sealing Plugs
- Floor Secured w/Torx Screws
- Cambered EZ Lube Axles
- Two 7,000# Cambered Axles w/2 Electric Brakes
- Complete Break-A-Way System w/Charger
- Spare Tire Mount (Side)
- 4' Slide-In Ramps (Channel)
- Grommet Mount Sealed Lighting

Dimensions			
Length	A	B	C
16'	193-1/2"	115"	78-1/2"
18'	217-1/2"	127"	90-1/2"
20'	240"	138"	102"

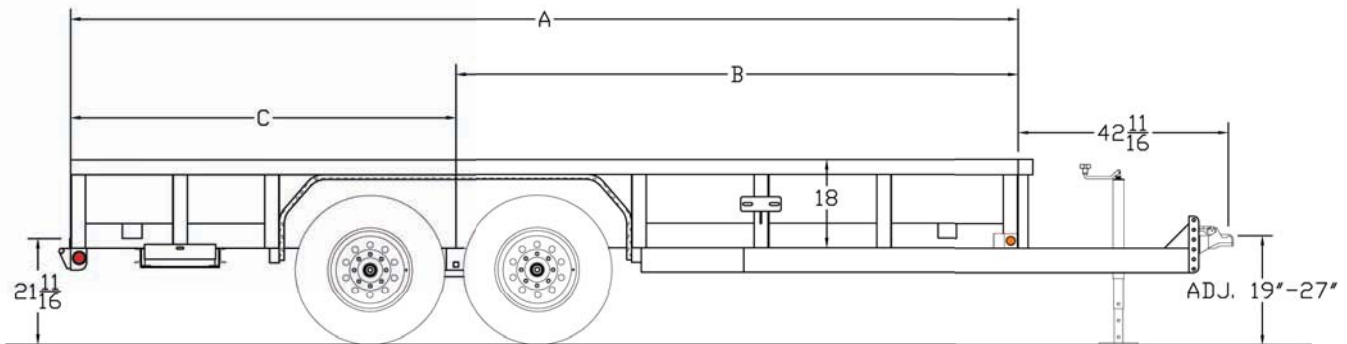

MODEL#	WEIGHT	DESCRIPTION
14PI-16	2,310#	83" x 16' Tandem Axle
14PI-18	2,470#	83" x 18' Tandem Axle
14PI-20	2,990#	83" x 20' Tandem Axle

OPTIONS

Adjustable Pintle in Channel	Spare Tire Upgrade (ST235/85 R-16 LR-G)
12K Top Wind Drop-Leg Jack	Rampgate in Lieu of Ramps
Hydraulic Brakes 2 Axles	Gas Spring Assist Option - Rampgate
Spare Tire (ST235/80 R-16 LR-E)	4' Heavy Duty Integrated Ramp Gate w/Gas Spring Assist in Lieu of Ramps
Tire Upgrade (ST235/85 R-16 LR-G)	5' Stand up Ramps in Lieu of Slide In