

# 14ET Tandem Axle Equipment

<b>G.V.W.R.</b>	14,000#	<b>AXLES</b>	Two 7,000# EZ Lube w/Electric Brakes
<b>G.A.W.R. (Ea. Axle)</b>	7,000#	<b>SUSPENSION</b>	Multi-Leaf Spring w/Equalizer
<b>COUPLER</b>	Adjustable Cast 2-5/16"	<b>TIRE</b>	ST235/16 Load Range E
<b>SAFETY CHAINS</b>	3/8" Grd. 70 w/Safety Latch Hook (2 each)	<b>WHEEL</b>	16 x 6 Radial Heavy White Mod 8 Bolt
<b>JACK</b>	7K TW Dropleg Jack (Bolted On)	<b>FLOOR</b>	2" Pine
<b>TONGUE</b>	6" Channel Fold Back	<b>LIGHTS</b>	D.O.T. Stop, Tail, Turn & Clearance
<b>TOP RAIL</b>	None	<b>ELEC. PLUG</b>	7-Way RV
<b>FRAME</b>	6" Channel	<b>FINISH (Prep)</b>	Steel is Cleaned to Ensure a Professional Smooth Finish.
<b>CROSSMEMBERS</b>	3" Channel on 16" Centers	<b>FINISH</b>	Superior Quality Finish is Applied with Pin-Stripping for a Highly Decorative and Protective Finish.
<b>UPRIGHTS</b>	None		
<b>FENDERS</b>	9" x 72" Diamond Plate w/Back (Removable)		

## Standard Features

- Adjustable Cast Coupler
- Safety Chains Atchd w/Cold Rolled Eyelets
- 7K Top Wind Drop Leg Jack
- Fold Back Tongue
- 2" Tubular Stop Rail
- Tie Down Pockets
- Floor Secured w/Torx Screws
- Reflective Marker Tape
- Cambered EZ Lube Axles
- Two 7,000# Axles w/Electric Brakes
- Complete Break-A-Way System w/Charger
- Spare Mount
- 32" Dovetail
- 5' Stand Up Ramps w/Adj. Support Legs

Shown with Optional 12K SW Jack

Dimensions			
Length	A	B	C
16'	193-1/2"	115"	78-1/2"
18'	217-1/2"	127"	90-1/2"
20'	240"	138"	102"

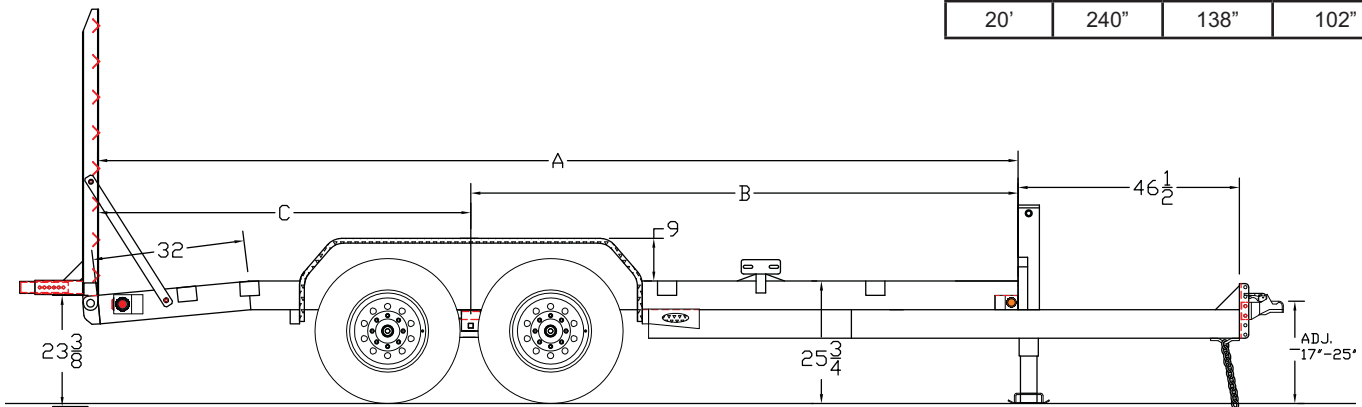

MODEL#	WEIGHT	DESCRIPTION
14ET-16	2,560#	83" x 16' Tandem Axle Equipment Trailer
14ET-18	2,710#	83" x 18' Tandem Axle Equipment Trailer
14ET-20	2,860#	83" x 20' Tandem Axle Equipment Trailer

### OPTIONS

Adjustable Pintle	Tire Upgrade (ST235/85 R-16 LR-G)
Hydraulic Brakes 2 Axles	Spare Tire Upgrade (ST235/85 R-16 LR-G)
Spare Tire (ST235/80 R-16 LR-E)	Gooseneck in Lieu of Bumper Pull